



本企业通过ISO9001国际质量体系认证  
Beijing Sanlu Factory has got ISO9001 Quality System Certificate

# BW850/5 型泥浆泵

## BW850/5 type mud pump

中探  
使用说明书

### An instruction manual

(安装、使用产品前，请阅读使用说明书)

Please read the instructions before installing and using the product

山东中探机械有限公司

Shandong Zhongtan Machinery Co., Ltd.

## 一、概述 Summary

BW850/5-90 型泥浆泵为卧式双缸双作用活塞泵,该泵的使用介质为泥浆,主要与 500 米的冻结钻、1000 米的注浆钻及 1000 米的水井钻配套使用,也适用于同参数的其它钻机配套。

BW850/5-90 mud pump is a horizontal double cylinder double acting piston pump, the pump for the use of medium and drilling mud, mainly frozen 500 meters, 1000 meters of drilling and grouting wells 1000 meters supporting the use of drilling, also applies to the other with the parameters of the drill rig.

本说明书依据 GB9969.1—1998《工业产品使用说明书总则》编写。

According to the specification GB9969.11998< industrial product specification general > writing.

本产品执行标准 This product implementation standard

企业标准: Q/SDZT001-2008《煤矿用泥浆泵》

Enterprise standard: Q/SDZT001-2008< coal mine mud pump >

国家标准: GB/T9234-1997《机动往复泵》

National standard: GB/T9234-1997< motor reciprocating pump >

## 二、使用范围和环境要求

### Scope of use and environmental requirements

本泵可分别在煤水浆或泥浆中正常工作,浆液介质必须符合下表的规定,并不得有泥团、树叶、草根、铁丝等杂物。

The pump can be respectively work in coal slurry or mud slurry medium, must comply with the provisions under the table, and there shall be no mud, leaves, roots, wire and other debris.

含沙量% Sediment concentration%	粘度 viscosity S	杂质颗粒 Impurity particle (mm)
<3.5	<30	2

泥浆池要求: 泵送介质的循环系统中返水沟不得短于 15 m, 泥浆沉淀池的有效深度不得小于 1.5 m。

Requirements of the mud pool: the return of the pump medium circulation system shall not be less than 15 m, the effective depth of mud settling tank shall not be less than 1.5 m.

## 三、型号意义 Model significance

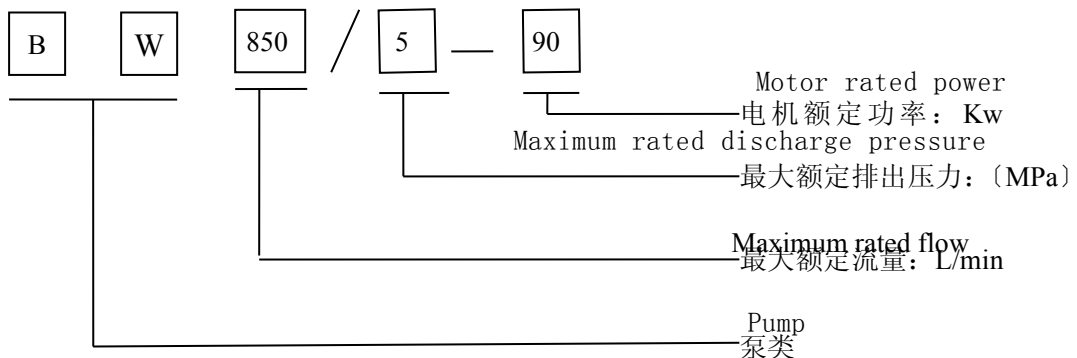

#### 四、主要技术参数 Main technical parameters

型式 type	卧式双缸双作用活塞式 Horizontal double cylinder double acting piston type
缸套内径 Cylinder liner (mm)	140
额定流量 Rated flow (L/min)	850
额定排出压力 Rated discharge pressure(Mpa)	5
行程长度 Stroke length (mm)	260
额定泵速 Rated pump speed ( $\text{min}^{-1}$ )	66
吸浆管直径 Suction pipe diameter (mm)	152
排浆管内径 Inside diameter (mm)	64
皮带轮直径 Pulley diameter (mm)	918
三角带 V-belt specification	MV-C6300-7
皮带轮转速 Pulley speed (r/min)	375
电机型号 Motor type	YBK2-280M-4
电机功率 Motor power (Kw)	90
电机转速 motor speed (r/min)	1480
容积效率 Volumetric efficiency (%)	90
总效率 Total efficiency (%)	75
主机重量 Host weight (Kg)	3100 (不含动力 Without power)
外形 Outline dimensionL*B*H (mm)	3018*1120*2050

## 五、结构介绍与工作原理

### Structure and working principle

BW850/5-90 型泥浆泵（附图 1）主要由离合器（6）、机架组（1）、泵体组（2）、空气包（3）、吸水龙头（8）及底座（7）等六部分组成。

BW850/5-90 type mud pump (Figure 1) is mainly composed of the clutch (6), the frame group (1), the pump body group (2), the air bag (3), the suction tap (8) and the base (7) and so on. Now the structure and its connection are introduced as follows:

The structure of each part and its connection are introduced as follows:

#### 1. 离合器（附图 2）Clutch (Figure 2)

离合器是泵的动力输入及离合器操纵装置，它安装于机架上，用两盘单列向心圆锥滚子轴承（4）支承着主动轴（5）。

The clutch is the power input of the pump and the clutch control device, which is installed on the machine frame, with two sets of single row radial tapered roller bearing (4) supporting the drive shaft (5).

主动轴的一端通过一对单列向心球轴承（19）支承着皮带轮（7），皮带轮内装有两组双面摩擦片（14），摩擦片又通过固定板（11）的花键孔与主动轴相联接，这样皮带轮的动力就通过摩擦片传给了主动轴。操作离合器操纵装置，通过顶杆（3）控制摩擦片的离合，即可控制皮带轮向主动轴的动力传递。

At one end of the drive shaft by a pair of single row radial ball bearing (19) supporting a pulley (7), with two sets of double side friction pulley (14), and the friction plate through the fixing plate (11) of the spline shaft connected with the driving pulley, this power is passed through a friction sheet the driving shaft operation control device. The clutch push rod (3) through the control of the clutch friction plate, can control the power of the drive shaft pulley to transfer.

离合器操纵装置为凸轮顶杆式。手把向下为合（开车），手把向上为离（停车）。

The clutch control device is the cam rod type. The handle is downward (driving), and the handle is up (off).

#### 2. 机架组（附图 3）Rack group (Figure 3)

机架组为整个泵的骨架，主要传动系统均装于其上。主动轴输入的回转运动通过曲轴连杆机构装置变为十字头拉杆的往复直线运动，并通过一对斜齿轮作一次减速。

A frame for the whole pump frame, main drive system are arranged on the rotary motion. The driving shaft input by a crankshaft connecting rod mechanism device into a reciprocating linear motion of crosshead rod, and through a pair of bevel gears to a deceleration.

曲轴通过两端两个单列向心圆锥滚子轴承（22）支承于机架组件（4）上，位于曲轴中间的齿轮又与主动轴上的齿轮相啮合，从而使曲轴得到了动力。在曲轴的两个曲柄上通过轴承（18）各装一连杆（17），连杆又通过连杆小头套（25）、十字头销轴（26）与十字头（7）相联接，十字头又与十字头拉杆（11）相联接，至此曲轴的转动变为十字头拉杆的往复直线运动。

The crankshaft through the two ends of single row tapered roller bearing (22) supported on a frame assembly (4), located in the middle of the crankshaft gear and the driving shaft of the gear meshing, so that the crankshaft has been in power. The two crank crankshaft through a bearing (18) are respectively provided with a connecting rod (17). The connecting rod through the connecting rod sleeve (25), crosshead pin (26) and (7) are connected to the crosshead, crosshead and crosshead

rod (11) is connected by the rotation of the crankshaft into reciprocating motion of crosshead rod.

机架滑板（6）安装于机架组件（4）上，十字头与机架滑板相配合。

The frame slide plate (6) is arranged on the frame assembly (4), and the cross head is matched with the frame slide plate

机架的前部装有盘根盒（8），盘根盒内装有盘根，以防止泥浆或其它污物窜入油池。十字头拉杆与十字头联接的左端用坚定螺钉（30）固定，防止十字头拉杆松动。在十字头拉杆的上方装有两个滴油杯（10），润滑拉杆。

The front part of the machine frame is equipped with a packing box (8) is arranged in the packing box, packing, in order to prevent mud or other contaminants into the oil tank. The crosshead rod and crosshead connected with screw (30) is firmly fixed, prevent the crosshead rod loosening. Two drip cup is arranged at the above the crosshead rod (10) lubrication, rod.

### 3. 泵体组（附图 4） Pump body group (Figure 4)

泵体组的作用为吸液和排液，用螺柱、螺母和机架连为一体。泵体内装有缸套及进排液阀，缸套的密封由“O”形密封圈和鼓形圈组成，以防止高压泥浆从缸套外壁窜流。活塞通过活塞套在活塞杆上，活塞杆又与十字头拉杆相联接，于是，达到吸排液作用，吸排液阀在弹簧的作用下，起到了及时地把高低压腔隔开的作用。

The pump group for suction and discharge, stud, nut and frame together. The pump body is provided with a cylinder and exhaust valve, cylinder seal ring and the drum circle is composed of "O" shape, in order to prevent high pressure mud from the external wall of the cylinder liner channeling piston through a piston in the piston sleeve. Rod, piston rod and crosshead rod is connected, so to suction fluid, suction and discharge valve under the action of the spring, played a role in a timely manner to the low pressure chamber separated.

泵体及进水管上的六角螺塞（17）起放水作用，长期放置不用时，要把泵体内积液放掉。

The pump body and the water inlet pipe of the six angle plug (17) from the water, not placed, the effusion pump body off.

### 4. 空气包（附图 5） Air bag (Figure 5)

空气包即蓄能器，它的作用是吸收泵的冲击压力，使整个系统的压力趋于平稳，保护高压系统的元件，有利于钻井施工。

The air accumulator is the accumulator, its function is to absorb the impact pressure of the pump, so that the pressure of the whole system tends to be stable, and the components of the high pressure system are protected

空气包的上端安装抗震压力表（6）一块，可以随时监视泵的工作压力。空气包的一侧安装着安全阀（7），它的作用是当泵压超过安全阀的设定压力值时，安全阀活塞开启，高压泥浆即从安全阀的排出口排出，使泥浆不过载，以确保泥浆泵的安全。要使安全阀复位，只需将离合器手把扳到空档位置，然后按下安全阀手柄即可。

The upper end of the air bag mounting seismic pressure gauge (6) one can always monitor the working pressure of the pump. The side air bag is provided with a safety valve (7), and its role is when the pump pressure exceeds the safety valve set pressure value, the piston opens the safety valve, high pressure mud is discharged from the discharge valve the mouth, the mud does not overload, to ensure the safety of mud pump. In order to enable the safety valve reset, only the clutch handle is turned to a neutral position, then press the valve handle.

空气包另一侧的接盘接高压胶管，往井下输送高压泥浆。

The other side of the air bag is connected with the high pressure rubber hose, and the high pressure mud is conveyed to the underground

整个空气包由六个 M20 螺柱和螺母联接在泵体上，由垫密封。

The whole air bag is connected to the pump body by six M20 screws and nuts

#### 5.吸水龙头（附图 6） Suction tap (Figure 6)

吸水龙头是泵的吸水系统，它由埋线胶管（4）、过滤器（1）等组成。它一方面是保障泵的吸入性能；另一方面可以过滤掉泥浆中的较大颗粒或杂物。

Water faucet is the suction system of the pump, which consists of a buried rubber hose (4), filter (1), etc. on the one hand, it is to protect the suction performance of the pump; on the other hand, it can filter out the larger particles or debris in the mud

为保障吸水系统的正常工作，及时清除过滤器外部的杂物是十分必要的。 In order to ensure the normal operation of the water absorption system, it is necessary to remove the impurities in the filter

#### 6.底座 base

底座为整机的安装基础，由槽钢焊接而成。可由动力拖动底座，使整个泵在地板上滑动，以利于路程不远的运输。

The base for the installation of the whole machine foundation, welded by the channel can be driven by the power base, so that the entire pump sliding on the floor, in order to facilitate the transport distance

#### 7.安全阀（附图 7） Safety valve (Figure 7)

##### < 1 > 安全阀开启压力的调整 Safety valve opening pressure adjustment

##### (1)调整原则： Adjustment principle:

一般情况下，不允许对安全阀的开启压力随意调整，只有在用户根据使用情况，对安全阀的开启压力要求低于出厂调定压力或在试压、使用过程中发现开启压力高于额定开启压力时，经检查未找出其它原因，能准确判断确由安全阀的开启压力调整不当所造成，才允许对安全阀进行调整，调整必须指定对安全阀结构和调整都熟练掌握的专门人员进行。

Under normal circumstances, do not allow the opening pressure of safety valve adjusted, only when the user according to the usage of the open pressure of safety valve set pressure or lower than the requirements of the pressure test, found in the course of opening pressure is higher than the rated opening pressure, the examination did not find other reasons, can be accurately judged by safety valve opening pressure adjustment caused by improper, is allowed to adjust the safety valve, safety valve adjustment must be specified to master the structure and adjustment of specialized personnel.

##### (2)调整方法和步骤 Adjustment methods and procedures

a 将螺母（28）松开 Loosen nut (28)

b 转动调整螺栓（29），顺时针转动，安全阀开启压力升高，逆时针为降低，每次转动不允许超过 1 / 4 圈，接近开启压力时，不允许超过 1 / 8 圈。

Turn the adjustment bolt (29), clockwise rotation, the safety valve opening pressure increases, counterclockwise to reduce, each rotation does not allow more than 1 / 4 laps, close to the opening pressure, do not allow more than 1 / 8 laps

c 试验开启压力合格后，将螺母（28）背紧，不合格需重复 a、b、c 内容。

After the opening of the test pressure, the nut (28) back, not qualified to repeat a, B, C content

##### (3)调整注意事项 Adjustment considerations

a 安全阀开启压力作升高调整时，一定要谨慎操纵，密切注意压力表压力（压力表不得损坏，必须准确），绝不允许超过泵额定排出压力的 1.05-1.15 倍，一旦超过应立即扳动三通水门或其它卸载设施进行卸载。

safety valve opening pressure for increased adjustment, must be careful manipulation, pay

close attention to the pressure gauge pressure (pressure gauge shall not be damaged, must be accurate), never allow 1.05-1.15 times more than the rated exhaust pressure of the pump, should immediately move once more than three gates or other facilities for unloading unloading.

b 做开启压力试验时，操作人员不得面对安全阀，应做好必要的防范措施，严防由于超压可能造成的意外事故的发生。

When opening the pressure test, the operator shall not face the safety valve, should do the necessary preventive measures to prevent excessive pressure may cause accidents

c 调整前后，都应对开启压力等值做好详细、准确的记录。

Before and after the adjustment, the pressure should be open to do a detailed and accurate record

< 2 > 夹布胶管的固定 Fixing of cloth hose

夹布胶管（1）的卡箍（2）必须卡紧。胶管的另一端及中间部位也必须固定，防止安全阀开启时胶管跳动。

The clamps (2) of the cloth clamping hose (1) must be tightened, and the other end and the middle part of the hose must also be fixed to prevent the rubber hose from beating when the safety valve is opened

< 3 > 安全阀的维护保养 Safety valve maintenance

安全阀在维护保养时，应在各滑动、转动部位浇注 30 #机油，防止锈蚀。

Safety valve in the maintenance, should be in the sliding, rotating parts of 30# oil to prevent rust

## 六、安装使用注意事项 Installation precautions

### 1 安装注意事项 Installation notes

(1) 泥浆泵应安装在枕木上，并用地脚螺栓固定。工作时泵不得摇晃。地基一定要夯实。

(1) Mud pump should be installed on the sleeper, and fixed with anchor bolts. When the pump can not be shaken

(2) 安装时必须找正，保证泥浆泵输入皮带轮轴与动力机输出轴平行，且皮带轮要与动力机组小带轮找正。

(2) the installation must be looking for is to ensure the mud pump input shaft pulley and power output shaft in parallel, and the pulley and the small belt pulley for power unit.

(3) 泥浆泵的转向应按皮带轮罩上箭头所指的方向运转，严禁任意改变。

(3) the steering of the mud pump shall be operated in accordance with the direction of the arrow on the belt wheel cover, and shall not be arbitrarily changed

(4) 皮带要给予一定的预紧力，皮带松弛会导致打滑，产生泵压和流量不足的现象，同时皮带容易出现打卷的现象，也会影响其使用寿命。

(4) the belt to give a certain preload, the belt will lead to slip skid, resulting in the phenomenon of insufficient pump pressure and flow, while the belt is prone to roll phenomenon, but also affect their life

(5) 根据地基情况，应自行配置好皮带罩，皮带罩应以安全、可靠为原则。

(5) according to the situation of the foundation, it is necessary to configure the belt cover, the belt cover should be safe and reliable

(6) 高压出水胶管的弯曲半径不得小于 1 m。

(6) the bending radius of the high-pressure water outlet hose shall not be less than 1m.

## 2 开车前的准备工作 Preparation before driving

(1) 检查泥浆泵机组的安装是否正确、牢固，各联接紧固件是否牢固、可靠，安全阀是否安装正确、可靠。

(1) check the installation of the mud pump unit is correct, firm, each connection fastener is firm, reliable, safety valve is installed correctly, reliable

(2) 离合器的动作是否灵活、可靠。

(2) the action of the clutch is flexible and reliable

(3) 检查各润滑部位、油池、油杯中润滑油是否充足。

(3) check the lubrication oil tank, oil cup, lubricating oil is sufficient.

(4) 检查吸水龙头的密封性能，并将吸水龙头处于泥浆池中部。检查空气包是否渗漏。

(4) check the sealing performance of the water tap, and the suction tap in the middle of the mud tank

(5) 检查压力表是否归零观察读数是否正常。

(5) check whether the pressure gauge is zero or not

(6) 开车前将低压腔灌满饮水。

(6) fill the low pressure chamber before driving

(7) 将离合器接合，用手拉皮带（手应远离带轮），进行盘车，此时应能缓慢转动，否则应检查各运动部件。

(7) the clutch engagement with a hand belt (belt wheel, hand away from) for barring, at this time



should be able to rotate slowly, you should check all moving parts.

(8) 该泵带三通水门，开车前必须将三通水门打开。

(8) the pump is equipped with a three - way water gate, which must be opened before the opening of the three way

(9) 开车前，离合器手把应处于分离位置。

(9) the clutch handle should be in a separate position before driving

### 3 运转中的操作及维护 Operation and maintenance in operation

(1) 开机后，应缓慢接合离合器，避免冲击。

(1) after the start, the clutch should be slow to avoid impact

(2) 先空转几分钟，观察各部位运转是否正常，有无异常震动、声响，观察泵的流量是否正常。发现异常应立即停车检查、排除。

(2) the first idle for a few minutes to observe the operation of each part is normal, there is no abnormal vibration, sound, observe the flow of the pump is normal

(3) 空运转正常后，应首先检查安全阀的压力是否正常，先将泵压缓慢升至开启压力，该泵出厂时将安全阀的开启压力调定为额定排出压力的 1.05-1.15 倍，如果泵压升至此范围时（绝对不允许超出此范围），安全阀仍未开启，应立即卸荷停车查找未正常开启的原因并及时予以排除，一般情况下不允许对安全阀的开启压力进行调整，除非在未查明其它故障原因后能准确判断确由安全阀的开启压力调整不当所造成时，必须严格按照安全阀的开启压力调整程序进行调整，同时必须做好安全阀压力调整数值详细、准确的记录。

(3) cargo to normal, should first check the safety valve pressure is normal, the pump pressure slowly to the opening pressure of the pump, the factory will be the safety valve opening pressure setting discharge pressure rated 1.05-1.15 times, if the pump pressure rise so far range (absolutely not allowed beyond this range). The safety valve is not open, why should immediately find the unloading parking is not normal open and timely excluded, under normal circumstances do not allow the opening pressure of the safety valve is adjusted, unless it did not find out other fault reasons can be accurately judged by the open pressure of safety valve caused by improper adjustment, must be strictly in accordance with the safety valve open Adjust the pressure adjustment procedure, at the

same time do a good job of safety valve pressure adjustment detailed and accurate records

(4) 在本节(2)、(3)都合格的情况下，可向井下缓慢输送泥浆，观察此时离合器是否打滑，压力脉动是否正常（不超过 1 MPa）有无其它异常情况，发现问题应立即停车检查，及时排除故障。

(4) the results in this section, are qualified under the condition to the underground slow transporting mud, then observe whether clutch slip, pressure fluctuation is normal (less than 1MPa) there are no other abnormalities, found the problem should immediately stop inspection, timely troubleshooting

## 七、维护保养 Maintenance

### 1 维护保养注意事项 Maintenance precautions

(1) 严防“三漏”（漏气、漏水、漏油）现象的发生，一旦发现应立即排除。

(1) to prevent the occurrence of the "three leakage" (leakage, leakage, oil spills) phenomenon, once found should be ruled out immediately

(2) 经常检查联接紧固件是否松动，保证牢固可靠。

(2) check whether the connecting fasteners are loose or not

(3) 注意保持外露运动零件及机器表面清洁，定期清除污垢。

(3) to keep the exposed moving parts and machine surface clean and remove dirt regularly

(4) 冬季（气温低于 0℃）作业，停机后可能造成冻结，若停机时间较短时，每隔 30 分钟需进行 5 分钟的空载泥浆循环运转，谨防堵塞或冻裂零部件事故的发生，长期停机时必须用清水冲洗残留于泵体内部和进出管路内部的介质，并放掉所有可能残留介质的腔内积水。

(4) (winter temperature below 0 DEG C) operation, shutdown caused by freezing, if the stop time is short, every 30 minutes to 5 minutes no-load mud circulation operation, beware of blocking or cracking parts accidents, long-term shutdown must wash the residue in the interior of the pump body and the internal medium with water inlet and outlet pipeline and, let go of all possible residual medium cavity water.

(5) 夏季用水泥浆做介质时，停机后可能造成泥浆凝固时，也必须及时用清水进行相应清洗，防止由于水泥浆凝固造成的堵塞现象，放置时间较长时也应该放掉腔内积水。

(5) summer medium with cement slurry do, after shutdown may cause mud solidification, must also

be timely use of water for cleaning, prevent the clogging caused by the solidification of cement slurry, place a long time should also let the accumulated water.

(6) 作业完毕后，应对整机进行相应的维护保养，除遵照上述(1)–(5)项内容外，可能长期放置时，还必须对机器内部有相对运动的零部件进行防锈处理。

(6) when the operation is completed, the maintenance of the corresponding response, except in accordance with the above 1 - the content, may be placed for a long time, also must have the relative movement of the parts of rust inside to the machine.

## 2 润滑注意事项 Lubrication matters needing attention

(1) 机架油池中的润滑油，冬季用 30#机油为宜，夏季用 40#机油为宜，油面以能浸没曲轴齿轮下端齿顶以上 120mm 为宜，并经常检查，定期更换。

(1) Rack oil pool in the oil, winter 30# oil is appropriate, in the summer with 40# oil is appropriate, the oil surface to be able to submerge the crankshaft gear teeth above the top of the 120mm is appropriate, and regular inspection, regular replacement

(2) 经常检查十字头、滑板处的润滑情况，油路始终保持畅通。

(2) always check the cross head, the lubrication of the sliding plate, and keep the oil line open

(3) 应保持机架上两油杯中润滑油充足和油路畅通。

(3) should be kept on an oil lubrication frame two is sufficient and unblocked.

(4) 离合器端部的油杯应保证每班注油一次。

(4) the end of the clutch should ensure that the cup class oiling once.

(5) 更换“V”形圈时各圈之间应填满黄油。

(5) grease should be filled between the rings when replacing the “V” ring

## 八、易损件的更换

### Replacement of wearing parts

#### 1、更换活塞 Replace piston

用手拉动皮带，使活塞处于最前位停下，用单头六方搬手（附图 8）拧下活塞杆上的螺帽，活塞杆连同活塞套一起拧下，更换新的活塞，重新装上。安装活塞时，应将其圆周表面涂上黄

油，以利于安装。

Pull the belt, so that the piston in the stop front and move hand with single head six (Figure 8) nut on the piston rod screw, piston rod and the piston sleeve screw, the replacement of the piston, re installed. Install the piston, the circumferential surface should be coated with butter, to easy to install.

## 2、 更换缸套 Replace cylinder

用取缸套工具（附图 1 0）按以下步骤即可卸下缸套：

Cylinder sleeve tool (Figure 10) according to the following steps to remove the cylinder liner:

用手拉动皮带，使活塞杆处于最里端，然后把顶板（2）水平放入缸顶套窗口内，把圆帽（1）套在活塞杆顶端，继续使皮带轮转动，使活塞杆往前行，缸套即被顶出一个行程（260mm），按上述步骤再顶一次，缸套即全被顶下来。

Pull the belt, the piston rod at the end, and then the roof (2) into the cylinder top level set in the window, the round cap (1) set at the top of the piston rod to make the pulley rotates, the piston rod forward, cylinder that was the top of a stroke (260mm), according to the the steps above again only once, the whole cylinder was the top down.

## 3、 更换活塞杆“V”形圈 Replace piston rod "V" ring

首先卸下活塞，再把活塞杆从拉杆上卸下来，这时既可换拉杆的盘根，也可换活塞杆上的“V”形圈，更换新的“V”形圈时，各圈之间要上些黄油。

First of all, remove the piston, and then remove the piston rod from the rod, which can not only change the rod packing, but also for the piston rod on the "V" shaped ring, the replacement of the new "V" shaped ring, the circle between the butter

## 4、 更换阀座 Change seat

用起阀座工具（附图 1 1）按以下步骤即可更换阀座。

With the seat tool (Figure 11) according to the following steps to replace the seat  
首先将锥锤（2）取出，用手把挡块（6）压入导管（5），调整尺寸 1 4 0 使之等于 1 4 5，

然后将法兰盘（4）固定在泵体上，下压锥锤使锥套（1）张开顶出挡块，这时用 $\varnothing 20$ 粗的钢棍一根插入导管与螺栓（3）的孔中，用力逆时针方向旋转即可卸下阀座。

The cone hammer (2) removed by hand block (6) is pressed into the catheter (5), adjust the size 140 is equal to 145, then the flange (4) is fixed on the pump body, under pressure to hammer cone sleeve (1) open top block, then the use of 20 thick steel stick a tube inserted into the bolt (3) and Kong Zhong, forcibly turned anti clockwise to remove the seat.

### 5、十字头与十字头拉杆拆卸注意事项

Cross head and crosshead pull rod disassembly

更换或拆卸十字头及十字头拉杆时，请注意先将十字头和十字头拉杆间的坚定螺钉（附图3中的序号10）卸掉。该螺钉位于十字头内，和拉杆成轴向安装。

When replacing or removing the crosshead and crosshead tie, please note that the first set of screws between the crosshead and crosshead tie (No. 3 in Figure 10) is removed. The screws are located in the crosshead and axially attached to the tie rod

### 九、常见故障的原因及排除

Causes and troubleshooting of common faults

故障名称 Fault name	产生原因 Cause	消除方法 Elimination method
1. 泵起动后不上水 No water pump starting	1. 吸水管及水腔有漏气的地方。 Suction pipe and water chamber where there is leakage 2. 吸水管及吸水笼头堵塞。 Water pipe and water tap clogging. 3. 起动太快。Start too fast 4. 吸水笼头阀门密封不严。 The watertap valve Mifengbuyan.	1. 排除漏气故障 Leakage fault 2. 清理堵塞部分。 Clear the blockage 3. 缓缓合上离合器。 Slowly close the clutch 4. 清理吸水笼头后灌水。 Clean the water tap after irrigation..

<p>2. 泵的排量不够</p> <p>Pump displacement is not enough</p>	<p>1. 吸水管有漏气的地方。</p> <p>There is a leak in the suction pipe</p> <p>2. 泥浆粘度大。Mud viscosity</p> <p>3. 吸水笼头进水管部分堵塞。</p> <p>The water tap water inlet pipe partially blocked.</p> <p>4. 动力转速不够。</p> <p>Dynamic speed is not enough</p> <p>5. 活塞或缸套磨损严重。</p> <p>Piston or cylinder liner wear serious</p> <p>6. 阀工作不正常或损坏。</p> <p>The valve is not working properly or damaged</p> <p>7. 离合器打滑。Clutch slip</p>	<p>1. 排除漏气故障。</p> <p>Exclude leakage fault</p> <p>2. 稀释泥浆。</p> <p>Dilute the mud</p> <p>3. 及时清理堵塞物。</p> <p>Clean up the blockage in time</p> <p>4. 调整转速，张紧三角带。</p> <p>Adjust the speed and tighten the V-belt</p> <p>5. 换新活塞或缸套。</p> <p>Replace the piston or cylinder</p> <p>6. 检查低压阀或阀座。</p> <p>Check the low-pressure valve or valve seat</p> <p>7. 修离合器。</p> <p>Repair the clutch</p>
<p>3. 压力表不稳，脉动量大于±0.5MPa</p> <p>The pressure gauge is unstable and the fluctuation is more than 0.5MPa</p>	<p>1. 高低压阀座磨损严重。</p> <p>High and low pressure valve seat wear</p> <p>2. 吸水笼头阀门失效</p> <p>Water faucet valve failure</p>	<p>1. 换新的。</p> <p>Change a new one.</p> <p>2. 清理和修理。</p> <p>Clean and repair</p>
<p>4. 运转中噪声异常，有冲击声</p> <p>Abnormal noise</p>	<p>1. 连杆小头铜套磨损严重。</p> <p>Connecting rod small copper sleeve wear serious</p>	<p>1. 换新的。</p> <p>Change a new one.</p> <p>2. 拧紧螺母。Tighten nut</p>

<p>during operation</p>	<p>2. 活塞相对活塞套杆移动。。 The piston moves relative to the piston rod</p> <p>3. 活塞拉杆与活塞杆联接处松动。 The piston rod is connected with the piston rod</p> <p>4. 主轴或曲轴轴承轴向间隙大。 Spindle or crankshaft bearing axial clearance</p>	<p>3. 拧紧卡箍上螺钉。 Tighten the screws on the clamps</p> <p>4. 调整主轴与曲轴端盖上的螺钉。 Adjust the screws on the spindle and the crankshaft cover</p>
<p>5. 活塞非正常损坏 Abnormal piston damage</p>	<p>1. 泥浆含沙量大。 The mud has a large sediment concentration</p> <p>2. 缸套磨损严重。 Cylinder liner wear serious</p> <p>3. 在不上水时长时运转。 Run long without water</p> <p>4. 启动时低腔没有灌水。 When the start of the low lumen without irrigation</p>	<p>1. 改善泥浆。Improve mud</p> <p>2. 换缸套。Cylinder liner</p> <p>3. 停车、查找原因。 Stop and find out why</p> <p>4. 灌水 irrigation</p>

## 十、贮存与保管 Storage and storage

泵使用完毕后，要及时清洗、检修保养，所有接头均涂润滑脂。

After the pump is used, it is necessary to timely cleaning, repair and maintenance, all the joints are coated with grease

泵应贮存在通风良好、防潮、无腐蚀性气体的仓库内。

Pump should be stored in a well ventilated, damp proof, non corrosive gas warehouse

## 十一、运输 transport

长距离的搬迁，应将泵放平放稳，底座固定牢固。

Long distance relocation, the pump should be placed flat and stable, the base fixed firmly

在起重、装卸、运输过程中，应注意保护压力表、安全阀。

In lifting, loading and unloading, transportation process, attention should be paid to protect the pressure gauge, safety valve

## 十二、成套供应及随机文件

### Complete supply and random file

1. BW850/5 型泥浆泵一台 BW850/5 type mud pump 1platform

2. KY-1 抗震压力表一块

KY-1 seismic pressure gauge 1block (ZG1 1/2" P=16Mpa)

3. 附属工具一套 Accessory tool 1set

4. 随机备件一套 Random spare 1set

5. 技术文件一套 Technical documents 1set

(1) 使用说明书一本 An instruction manual 1book

(2) 装箱清单一份 Packing list 1share

(3) 产品合格证一份 Product certificate 1share

附表 1 泥浆泵安装轴承表 Mud pump mounting bearing table

序号 Serial number	型号 Model	名称 Name	数量 Number	规格 Specifications	安装部位 Installation position
1	NUP1052	圆柱滚子轴承 Cylindrical roller bearing	2	Φ 260× Φ 400× 65	2106-02
2	30324	调锥滚子轴承 Taper roller bearing	2	Φ 120× Φ 260× 60	2106-02



3	30319	圆锥滚子轴承 Tapered roller bearing	2	$\phi 95 \times \phi 200 \times 50$	K62-1
4	6318	深沟球轴承 Deep groove ball bearing	2	$\phi 90 \times \phi 190 \times 43$	K62-1
5	6206	深沟球轴承 Deep groove ball bearing	2	$\phi 30 \times \phi 62 \times 16$	K62-1

附表2 随机工具 Random tools

序号 Serial number	代号 Code	名称 Name	数量 Number	用途 purpose
1	2106G-01	起阀座工具 Lifting tool	1	起阀座 Starting seat
2	2106G-02	单头六方扳手 Single head six square wrench	1	起活塞杆螺母 Piston rod nut
3	K62-G-5	取缸套工具 Cylinder tool	1	取缸套 Cylinder liner

十三、附图 Figure

代号 Code	2106	名称 Name	泥泵泵 mud pump
序号 Serial number	代号 Code	名称 Name	数量 Number
		名称 Name	备注 Remarks
1	2106-02	机架组 Rack group	1
2	2106-01	泵体组 Pump group	1
3	K62-4	空气包 Air bag	1
4	K62-4-1	安全阀 Safety valve	1
5	YK-1	抗震压力表 Seismic pressure gauge	1
6	K62-1	离合器 Clutch	1
7	2106-04	底座 base	1
8	K62-5	吸水龙头 Suction tap	1

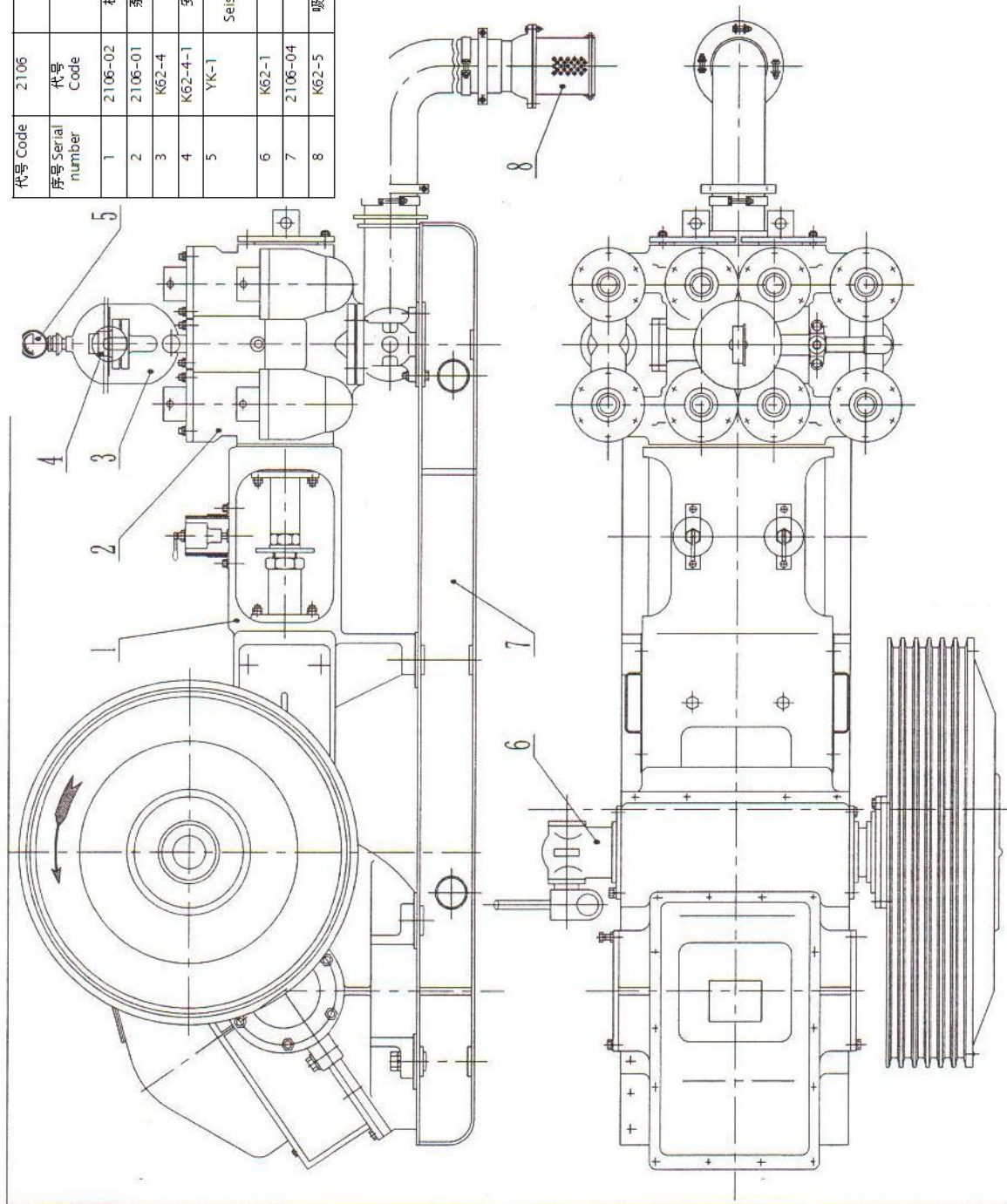

附图 1

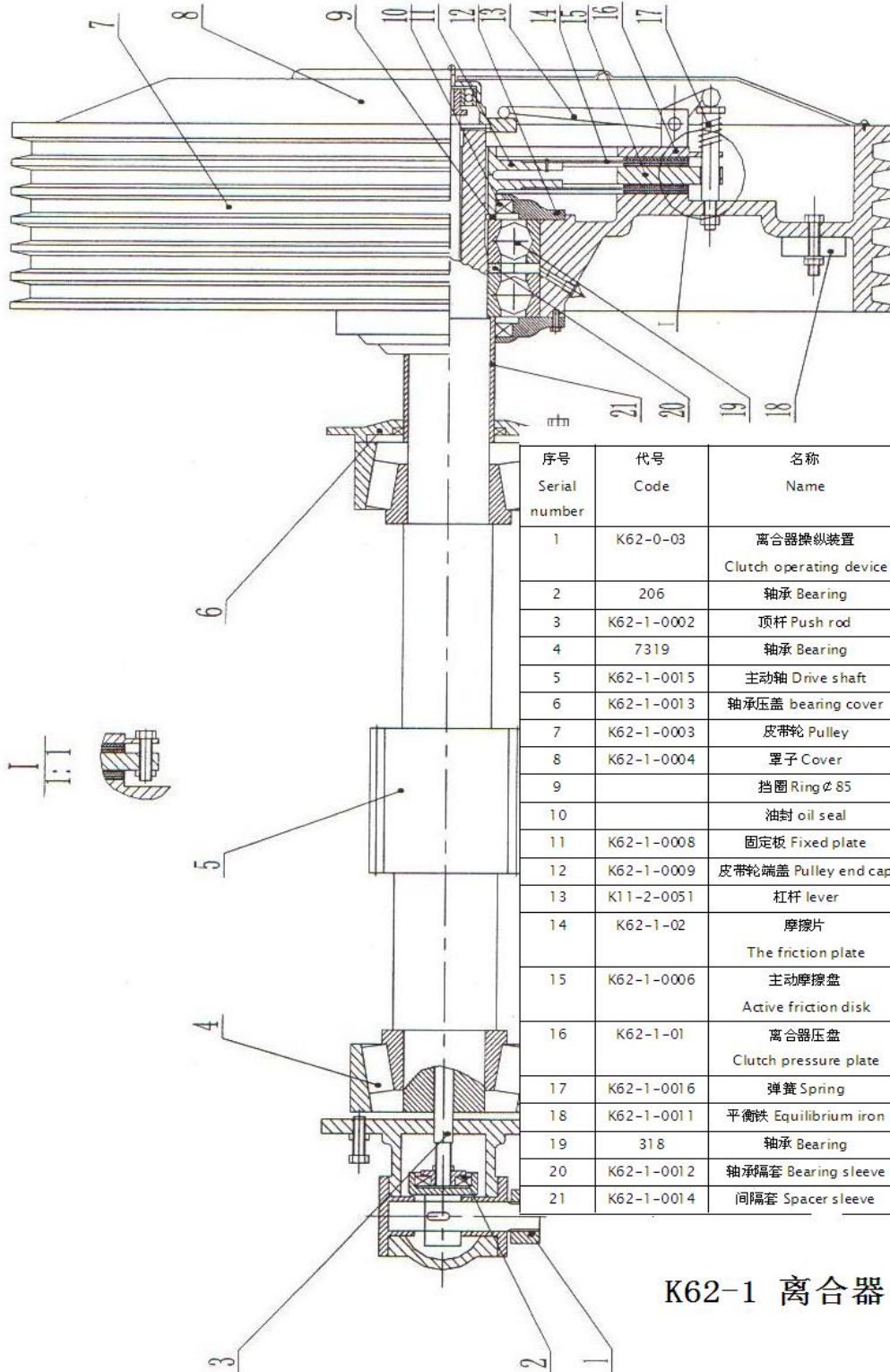

序号 Serial number	代号 Code	名称 Name	数量 Number	备注 Remarks
1	K62-0-03	离合器操纵装置 Clutch operating device	1	
2	206	轴承 Bearing	2	30*62*16
3	K62-1-0002	顶杆 Push rod	1	
4	7319	轴承 Bearing	2	90*200*50
5	K62-1-0015	主动轴 Drive shaft	1	
6	K62-1-0013	轴承压盖 bearing cover	1	
7	K62-1-0003	皮带轮 Pulley	1	
8	K62-1-0004	罩子 Cover	1	
9		挡圈 Ring $\phi$ 85	1	GB8941-96
10		油封 oil seal	2	110*140*12
11	K62-1-0008	固定板 Fixed plate	2	
12	K62-1-0009	皮带轮端盖 Pulley end cap	2	
13	K11-2-0051	杠杆 lever	6	
14	K62-1-02	摩擦片 The friction plate	2	
15	K62-1-0006	主动摩擦盘 Active friction disk	1	
16	K62-1-01	离合器压盘 Clutch pressure plate	1	
17	K62-1-0016	弹簧 Spring	12	
18	K62-1-0011	平衡铁 Equilibrium iron	3	
19	318	轴承 Bearing	2	90*190*43
20	K62-1-0012	轴承隔套 Bearing sleeve	1	
21	K62-1-0014	间隔套 Spacer sleeve	1	

K62-1 离合器

序号 Serial number	代号 Code	名称 Name	数量 Number	备注 Remarks
1	K62-2-0001	盖板 Cover plate	1	
2	K62-2-02	泵盖 Pump cover	1	
3	K62-2-0003	压板 Plate	4	
4	K62-2-01	机架零件 Rack Mount Kits	1	
5	K62-0-0004	纸垫 Paper pad	1	
6	K62-2-0006	机盖衬板 Rack slide	4	
7	K62-2-0007	十字头 Crosshead	2	
8	K62-2-0009	套圈盒 packing box	2	
9	K62-2-0010	套圈压盖 packing gland	2	
10		轴衬 200 200 cup	2	GB1158-74
11	K62-2-0011	十字头拉杆 Crosshead rod	2	
12	SMB1210-1	压环 Pressure ring	2	
13	SMB1210-2	密封环 Sealing	6	
14	SMB1210-3	支撑环 Support ring	2	
15	K62-2-0012	压板 Plate	2	
16	SMB1-71	油塞 M20*1.5 Oil plug M20*1.5	3	
17	K62-2-0013	连杆 connecting rod	2	
18	92152	单列向心球轴承 Single row radial ball bearing	2	260*400*65
19	K62-2-0014	轴套盖 Bearing cap	2	
20	K62-2-0025	曲轴齿轮 Crankshaft gear	1	
21	K62-2-0015	垫板 垫板	2	
22	7324	单列圆锥滚子轴承 Single row tapered roller bearing	2	120*260*60
23	K62-2-0016	弹性挡圈 Elasticretainer ring	2	
24	K62-2-0017	挡铁 baffle	2	
25	K62-2-0018	连杆小头套 Connecting rod cap	2	
26	K62-2-0019	十字头销轴 Crosshead pin	2	
27		平键 8*18 Flat key 8*18	2	GB1096-72
28	K62-2-0023	垫板 垫板	2	
29	K62-2-04	盖板 Cover plate	2	

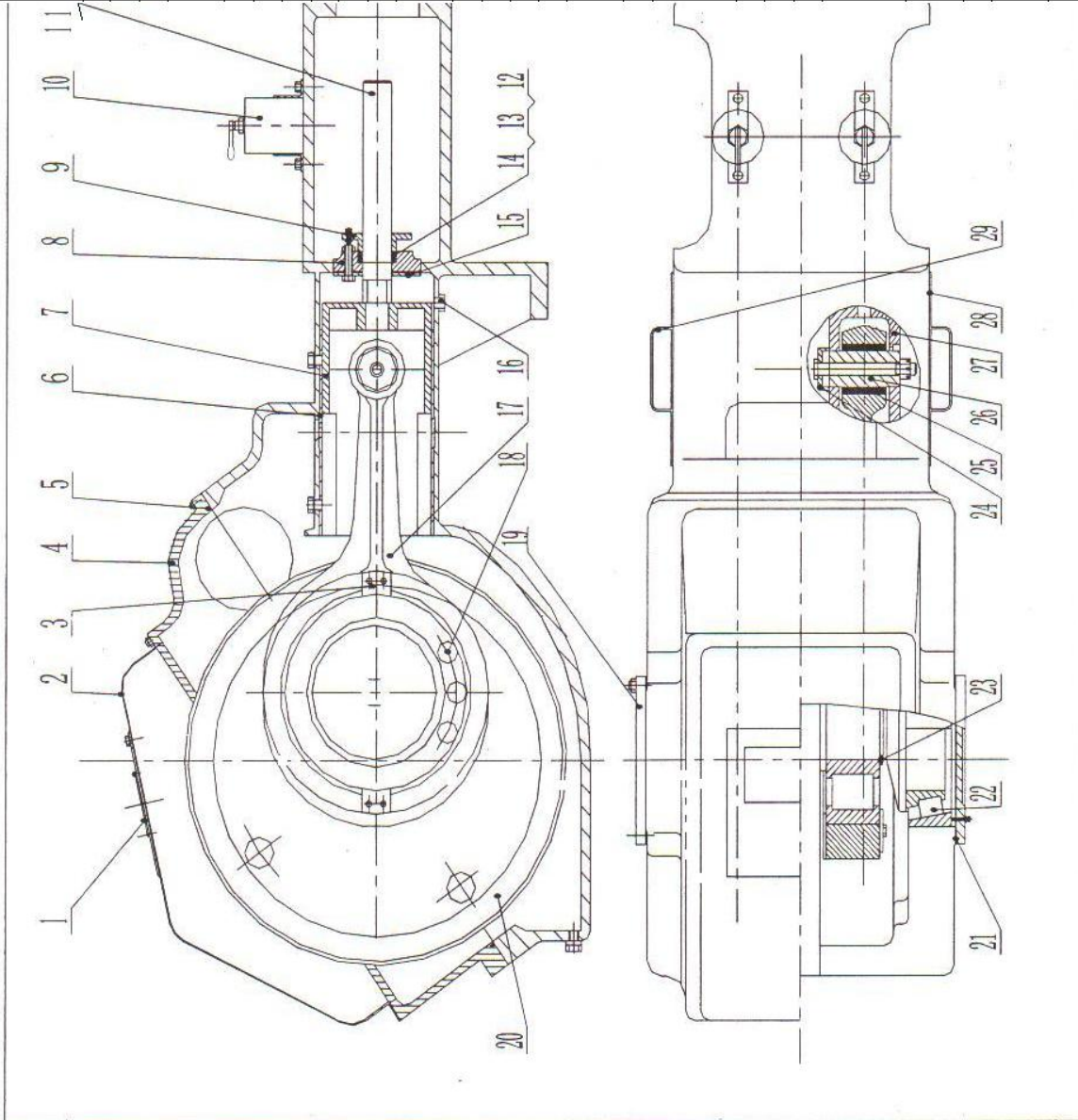

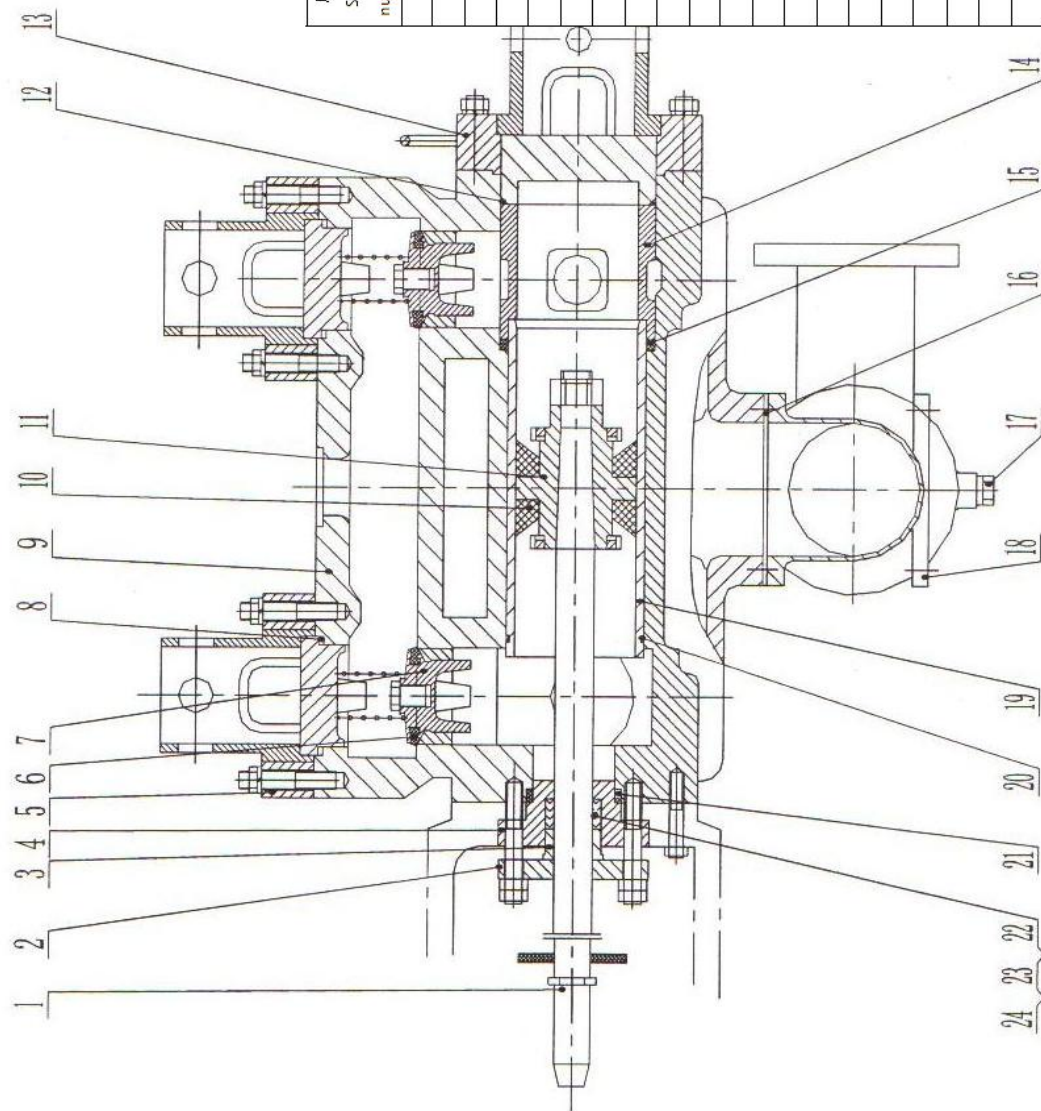

序号 Serial number	代号 Code	名称 Name	数量 Number	备注 Remarks
1	2106-01.4	活塞杆 Piston rod	2	
2	K62-3-0003	压板 Plate	2	
3	K62-3-0005	压套 Set pressure	2	
4	K62-3-0006	密封盘 Seal plate	2	
5	2106-01.2	法兰 flange	4	
6	K62-3-0202	阀垫 Valve pad	8	
7	K62-3-0201	阀脚 Foot valve	8	
8	Q/SM1235-2002	O型密封圈 O type seal ring	8	Φ135*5.7
9	2106-0101	泵体 Pump body	1	
10	K62-3-05	大活塞 Big piston	4	
11	K62-3-0018	大活塞套 Large piston sleeve	4	
12	Q/SM1235-2002	O型密封圈 O type seal ring		Φ180*8.6
13	2106-0104	左缸法兰 Left cylinder flange	1	
14	2106-01.6	缸顶套 Cylinder cap	2	
15	K62-3-0013	鼓型圈 Drum ring	2	
16	K62-3-0019	胶垫 Rubber pad	2	
17	Q/ZB220.6-77	六角油塞 Six angle oil plug	7	M20*1.5
18	K62-3-03	进水管 Inlet pipe	1	
19	K62-3-04	大缸套 Large cylinder	2	
20	K62-3-0007	鼓型圈 Drum ring	2	
21	SMB1219-1	压环 Pressure ring	2	
22	SMB1219-2	密封环 Seal ring	16	
23	SMB1219-3	支撑环 Support ring	2	

附图 4

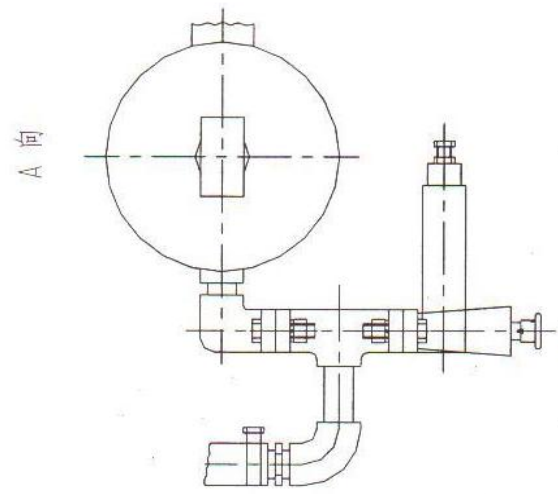
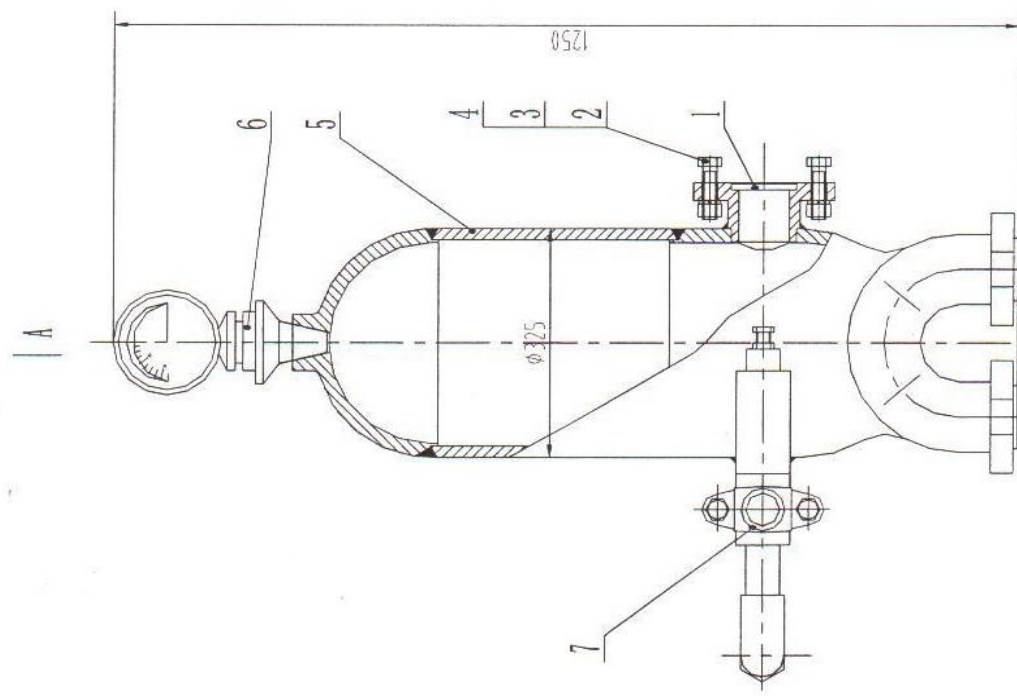

序号 Serial number	代号 Code	名称 Name	数量 Number	备注 Remarks
1	K62-4-0002	垫片 pad	1	
2	GB5783-86	螺栓 M20*75 Bolt M20*75	6	
3	GB6170-86	螺母 M20 Nut M20	6	
4	GB93-87	垫圈 20 Washer 20	6	
5	K62-4-01	气包体 Inclusion body	1	
6	YK-1	抗震压力表 Seismic pressure gauge	1	0~160Kg/cm
7	K62-4-1	安全阀 Safety valve	1	$\phi 100$ 1 1/2

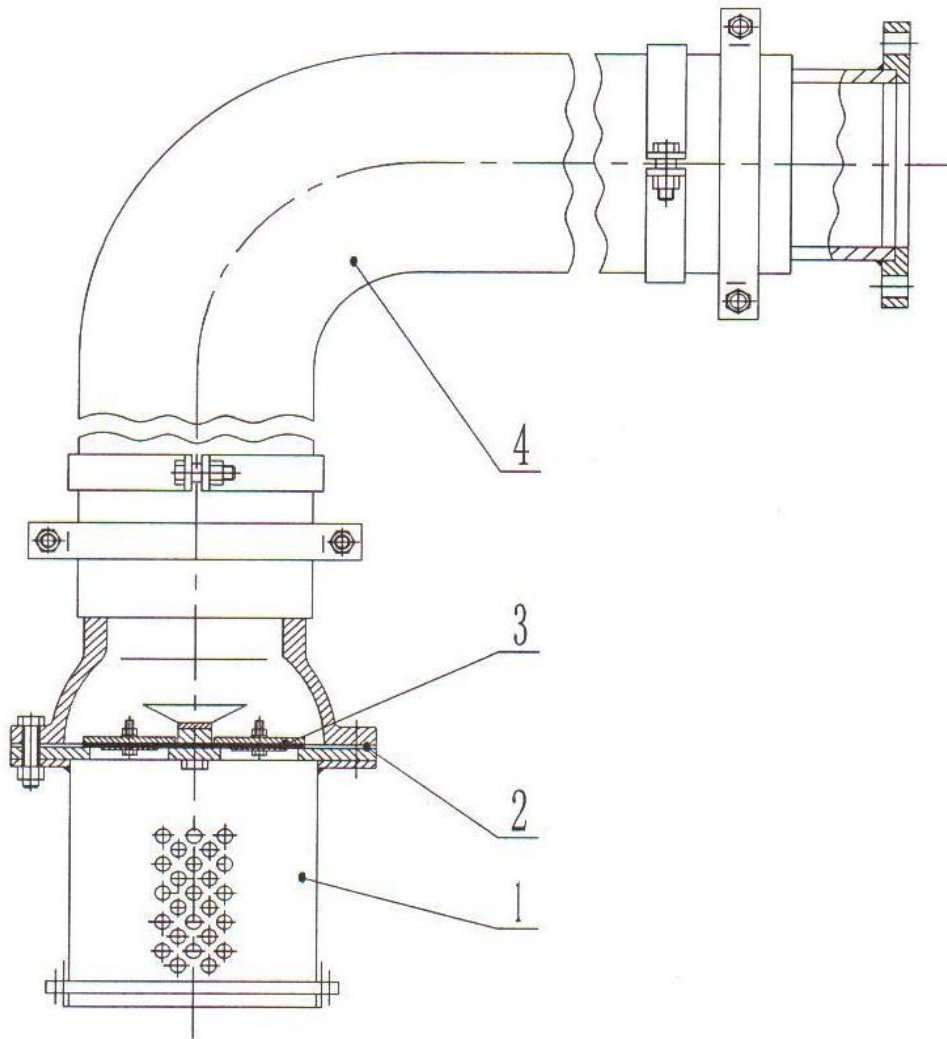

序号 Serial number	代号 Code	名称 Name	数量 Number	备注 Remarks
1	K62-5-1	过滤器 Filter	1	
2	K62-5-0001	垫圈 Washer	1	
3	K62-5-0005	阀盘 The valve disc	1	
4		埋线胶管 Catgut embedding	1	6 层帆布胶管内径 $\Phi$ 152 长 9 米 6 layers of cloth hose diameter 152 mm length of 9 meters

附图 6



图 7 安全阀部装图

序号 Serial number	代号 Code	名称 Name	数量 Number	备注 Remarks
1	K62-4-1-01	阀盖 Cover	1	
2	GB86-85	螺钉 M12*50 Screw M12*50	1	
3	GB170-86	螺母 AM12Nut AM12	1	
4	GB854-87	垫圈 12 Washer 12	1	
5	GB67-85	螺钉 M5*6 Screw M5*6	1	
6	K62-4-1-02	阀盖 Valve cover	1	
7	K62-4-1-03	弹簧座 Spring seat	1	
8	K62-4-1-04	阀体 valve body	1	
9	K62-4-1-05	弹簧 Spring	1	
10	K62-4-1-06	安全阀铁堵 Safety valve plug	1	
11	K62-4-1-07	钢球 steel ball	1	
12	GB1235-76	O 型密封圈 60*3.1 O type sealing ring 60*3.1	1	



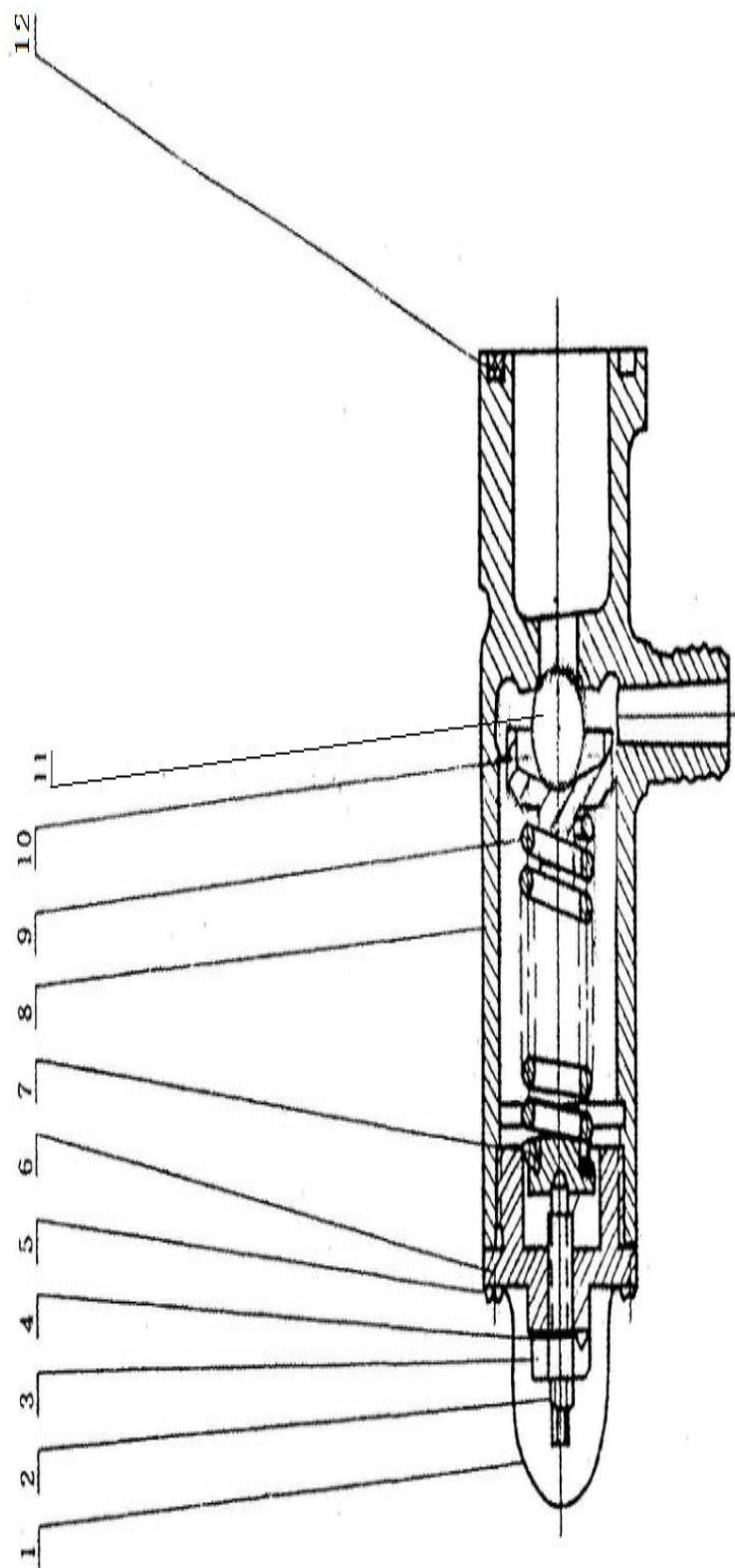
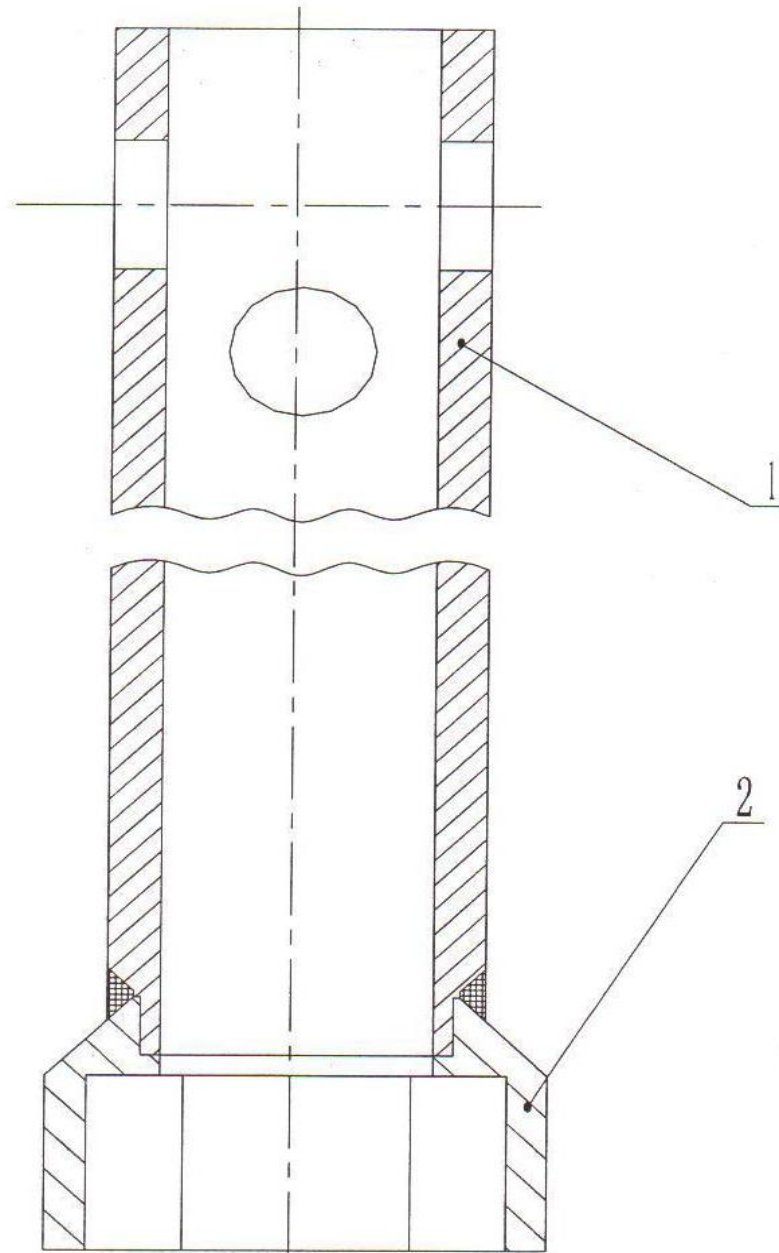

序号 Serial number	代号 Code	名称 Name	数量 Number	备注 Remarks
1	K62-G-2-0001	内六方搬子 Six party mobile	1	
2	2106G-02.1	套筒 Sleeve	1	

附图 8

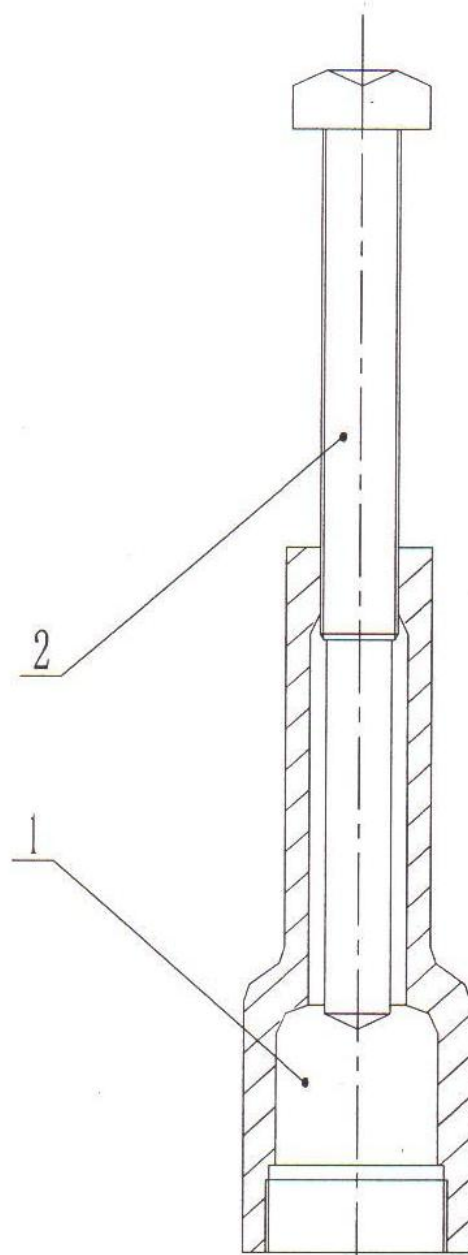

序号 Serial number	代号 Code	名称 Name	数量 Number	备注 Remarks
1	2106G-03.1	套 set	1	
2	2106G-03.2	顶杆 Push rod	1	

附图 9

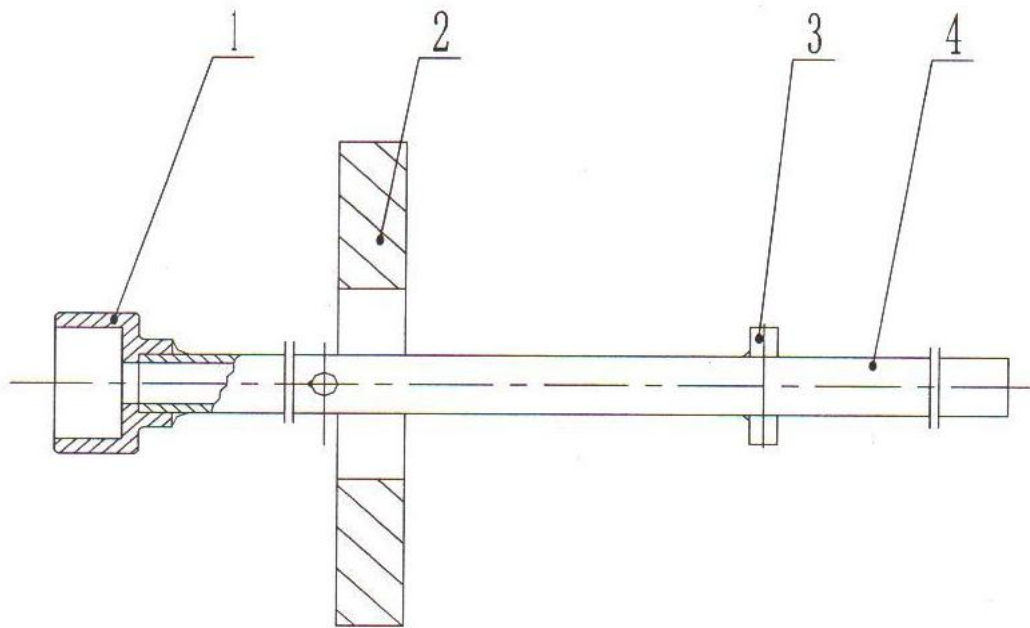

#### 使用方法 Usage method

用手转动皮带轮，使活塞杆处于最里端，然后把顶板水平放入缸顶套内，把圆套套在活塞杆顶端，继续转动皮带轮，使活塞杆往前行，缸套即被顶出（260mm），按上述步骤再顶一次，缸套即全被顶下来。

Turn the pulley by hand, so that the piston rod at the end, and then put into the roof horizontal cylinder top cover, the circle is sleeved on the piston rod end, continue to turn the pulley, the piston rod forward, which was the top of the cylinder (260mm), according to the above steps again only once, which was the top liner down

序号 Serial number	代号 Code	名称 Name	数量 Number	备注 Remarks
1	K62-G-5-0001	圆帽 Round cap	1	
2	K62-G-5-0002	顶杆 Push rod	1	
3	K62-G-5-0003	顶板 roof	1	
4	GB119-86	销 D8*40 Pin D8*40	2	

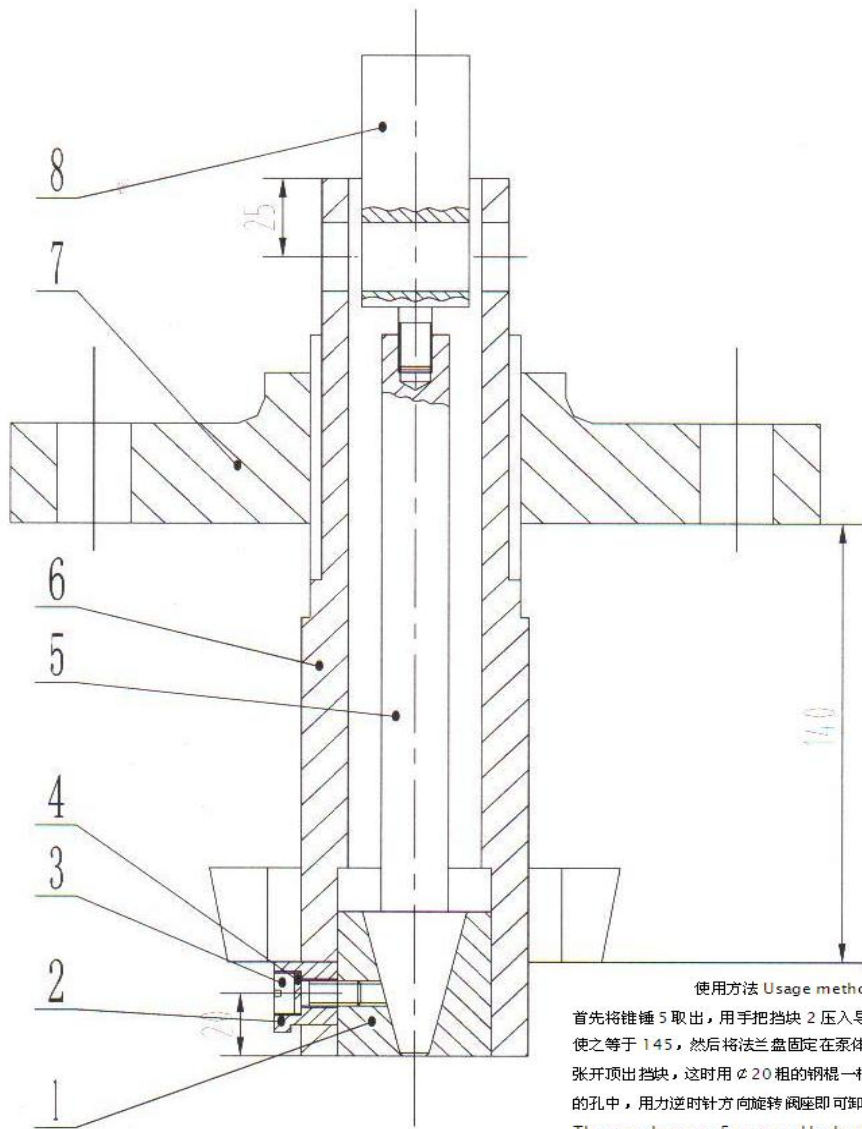

使用方法 Usage method

首先将锥锤 5 取出，用手把挡块 2 压入导管，调整尺寸 140 使之等于 145，然后将法兰盘固定在泵体上，下压锥锤使锥套张开顶出挡块，这时用  $\varnothing 20$  粗的钢棍一根插入导管 6 及螺栓 8 的孔中，用力逆时针方向旋转阀座即可卸下。

The cone hammer 5 removed by hand block 2 is pressed into the catheter, adjust the size to 140 is equal to 145, then the flange is fixed on the pump body, under pressure cone sleeve top hammer to open block, this time with 20 of crude steel stick a tube inserted into the bolt and Kong Zhong 6 8, to force the counterclockwise rotating seat can be unloaded.

序号 Serial number	代号 Code	名称 Name	数量 Number	备注 Remarks
1	K62-G-1-0001	锥套 Taper sleeve	1	
2	K62-G-1-0002	挡块 Block	3	
3	GB65-85	螺钉 M8*25 Screw M8*25	3	
4	GB93-87	垫圈 8 Washer 8	3	
5	K62-G-1-0003	锥锤 Cone hammer	1	
6	K62-G-1-0004	导管 catheter	1	
7	2106G-01.1	法兰盘 Flange	1	
8	K62-G-1-0006	螺栓 Bolt	1	

附图 11



山东中探机械有限公司

Shandong Zhongtan Machinery Co., Ltd.

地址：山东高唐高新技术开发区

Address: Gaotang high tech Development Zone, Shandong

销售服务热线：0635-3993708 6912799

Sales service hotline: 0635-3993708 6912799

传真：0635-6912798

Fax: 0635-6912798

邮编：252800

Zip code: 252800

(产品设计及规格变更，恕不另行通知)

(product design and specification change without notice)